

# NEW CONSTRUCTION OF DUPLEX DWELLING

BLOCK 617, LOT 3 (AA - RESIDENTIAL DISTRICT ZONE)  
72 WEST RUBY AVENUE, PALISADES PARK, NJ



KEY MAP SCALE: N.T.S.

ZONING COMPLIANCE	REQUIRED	PROPOSED	VARIANCE REQ'D
MIN. LOT AREA	5,000 SF	5,000 SF	NO
MIN. LOT FRONTAGE	50 FT	50 FT	NO
DWELLING UNIT	TWO	TWO (DUPLEX)	NO
LOT AREA PER UNIT	2,500 SF	2,500 SF	NO
MAX. COVERAGE	2,000 SF (40%)	2,090 SF (41.8%)	YES
MIN. FRONT YARD	19.04 FT (AVG.) 20.00 FT (MIN.) 35.00 FT (MAX)	20.00 FT	NO
MIN. SIDE YARDS (BOTH)	12 FT	12.00 FT	NO
MIN. SIDE YARDS (EACH)	6 FT	6.00 FT	NO
		6.00 FT	NO
MIN. REAR YARD	25 FT	25 FT	NO
MAX. BUILDING HEIGHT	2-1/2 ST / 28 FT	2-1/2 ST / 31.10 FT	YES

IT IS A VIOLATION OF NEW JERSEY STATE LAW TO ALTER PLANS, SPECIFICATIONS OR REPORTS TO WHICH THE SEAL OF AN ARCHITECT HAS BEEN APPLIED.

PROJECT TITLE

**72 WEST RUBY AVENUE**

72 WEST RUBY AVENUE,  
PALISADES PARK, NEW JERSEY

CONSULTANT

ARCHITECT

**MG**

ARCHITECTURE + URBANISM, LLC

MG ARCHITECTURE URBANISM, LLC  
580 Sylvan Avenue, Suite 2C  
Englewood Cliffs, NJ 07632  
T.646.335.3515  
info@mg-ua.com

STAMP

PETER C. PARK  
RA, AIA, NCARB, LEED AP ND  
NJ ARCHITECT: AI-20070

NO.	DATE	REVISION
02	05.11.2021	ZONING REVIEW
01	01.29.2021	ENGINEER REVIEW

DOB APPROVAL STAMP

DOB NO.

ISSUED DATE 05/11/2021

PROJECT NUMBER 20019

SCALE AS NOTED

SHEET NAME

**ZONING INFO,  
SITE PLAN  
& ELEVATIONS**

SHEET NUMBER

**Z-101**

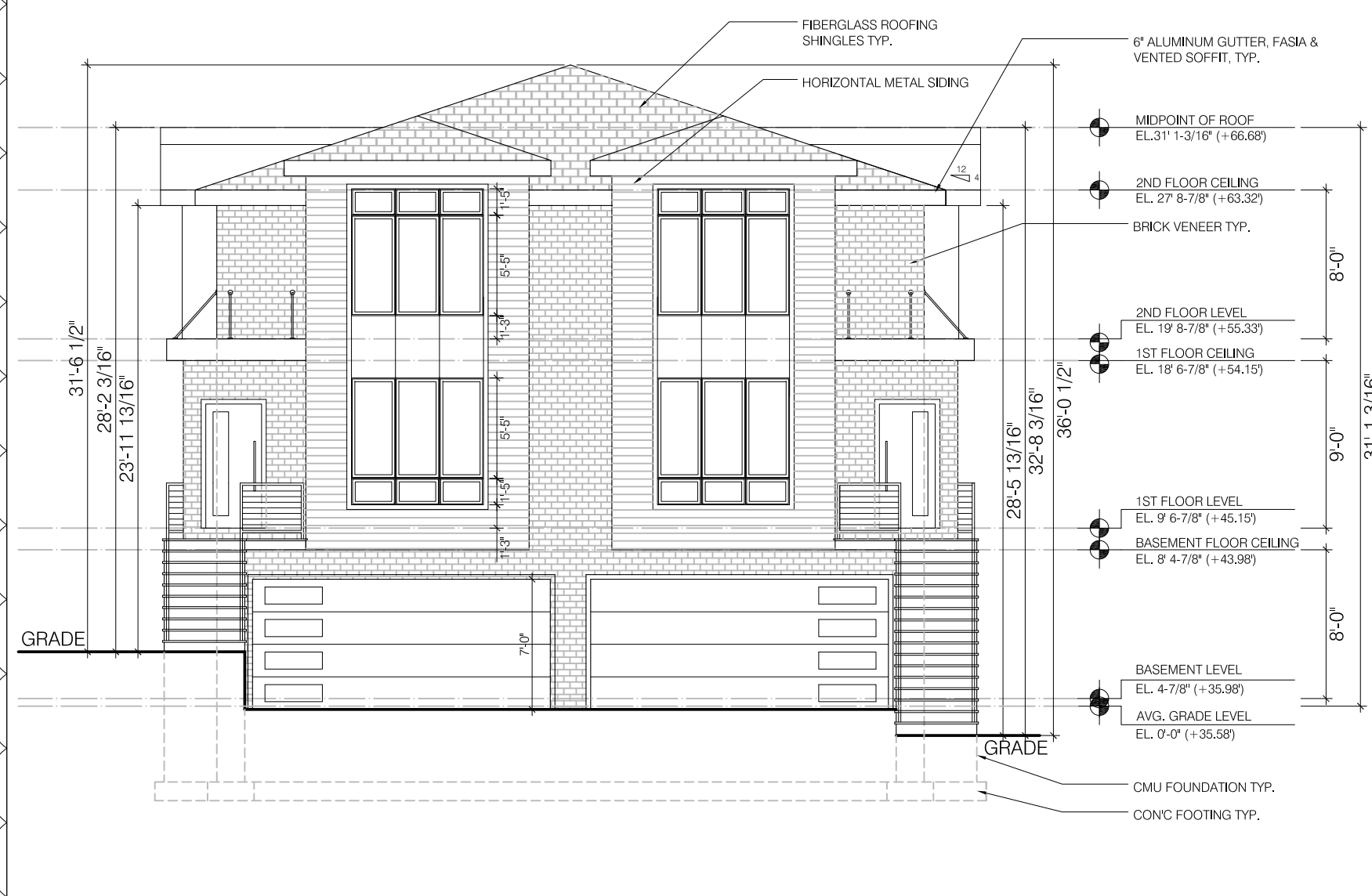

2 NORTH ELEVATION  
SCALE: 1/8"=1'-0"

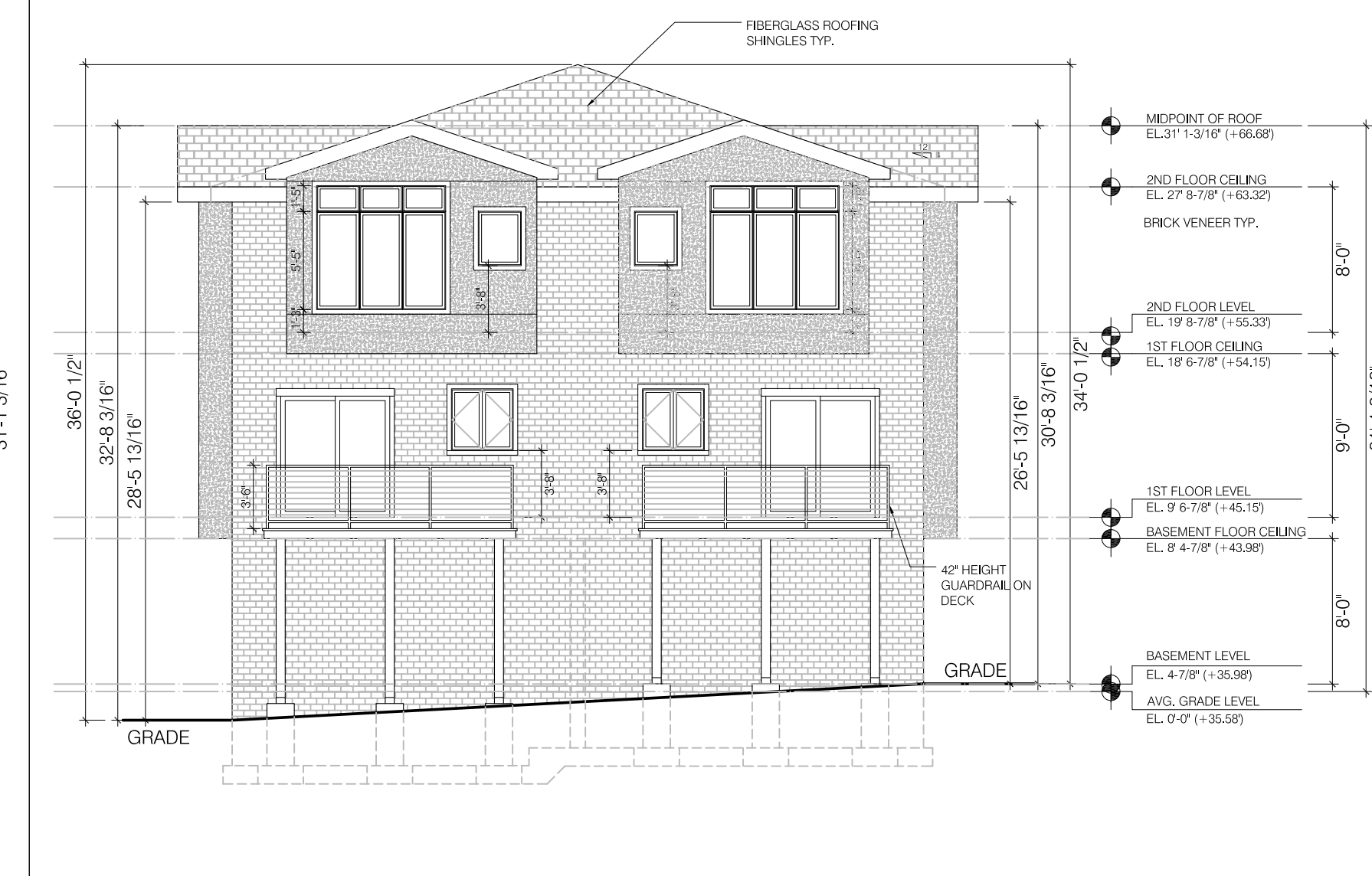

3 SOUTH ELEVATION  
SCALE: 1/8"=1'-0"



4 WEST ELEVATION  
SCALE: 1/8"=1'-0"



5 EAST ELEVATION  
SCALE: 1/8"=1'-0"

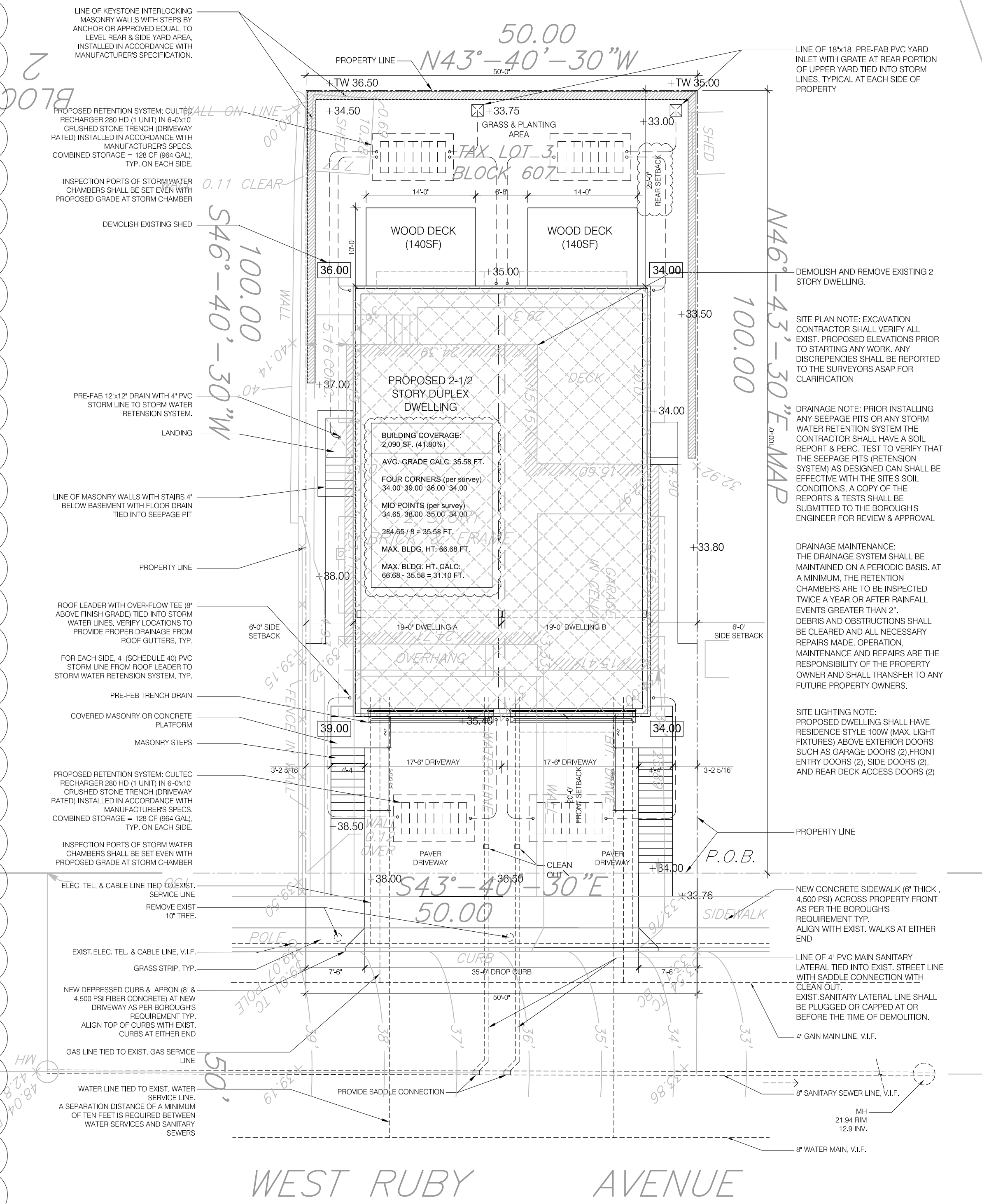

1 SITE SURVEYOR'S DRAWING WITH PROPOSED SITE WORK  
SCALE: 1\"/>





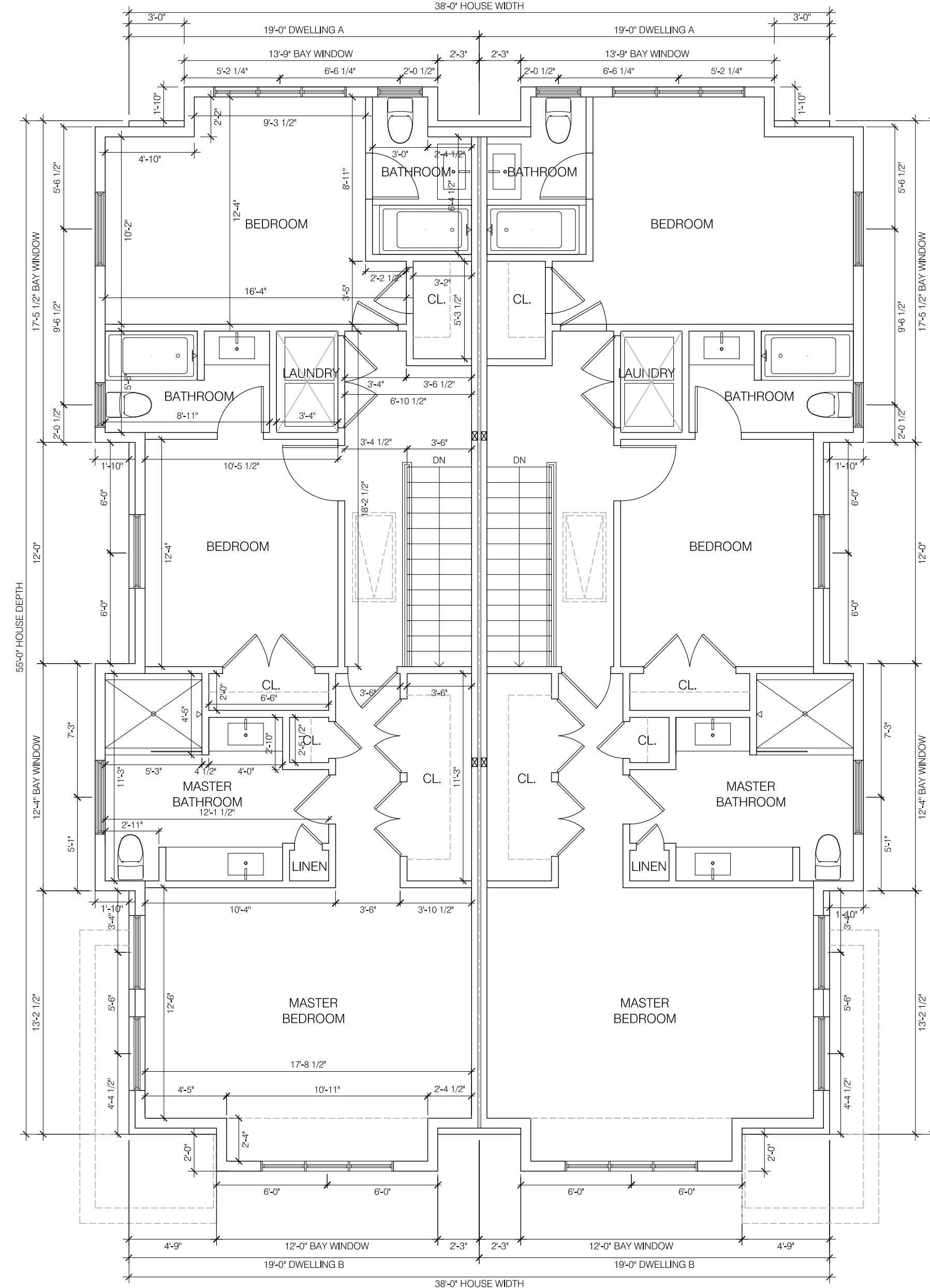
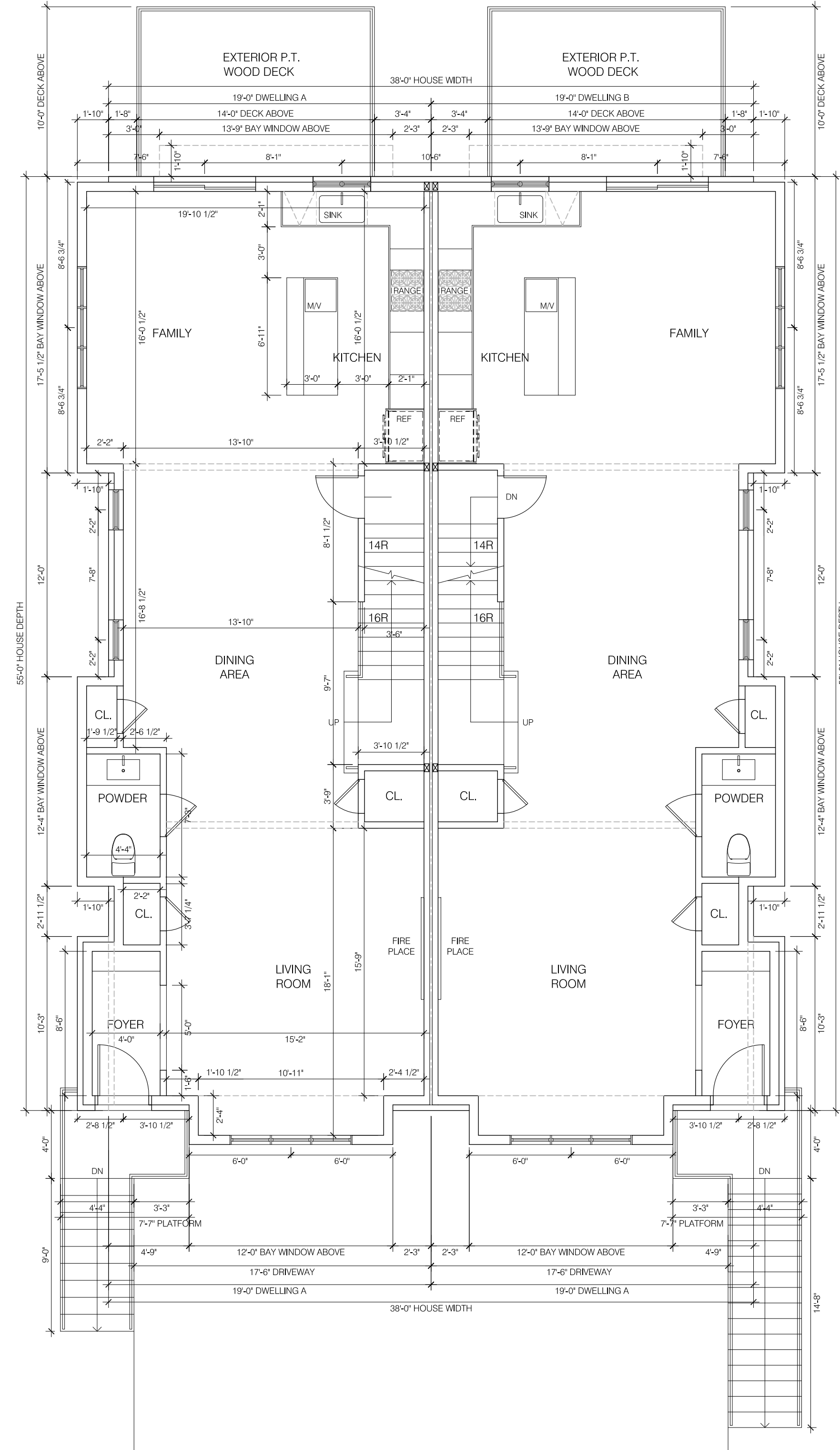
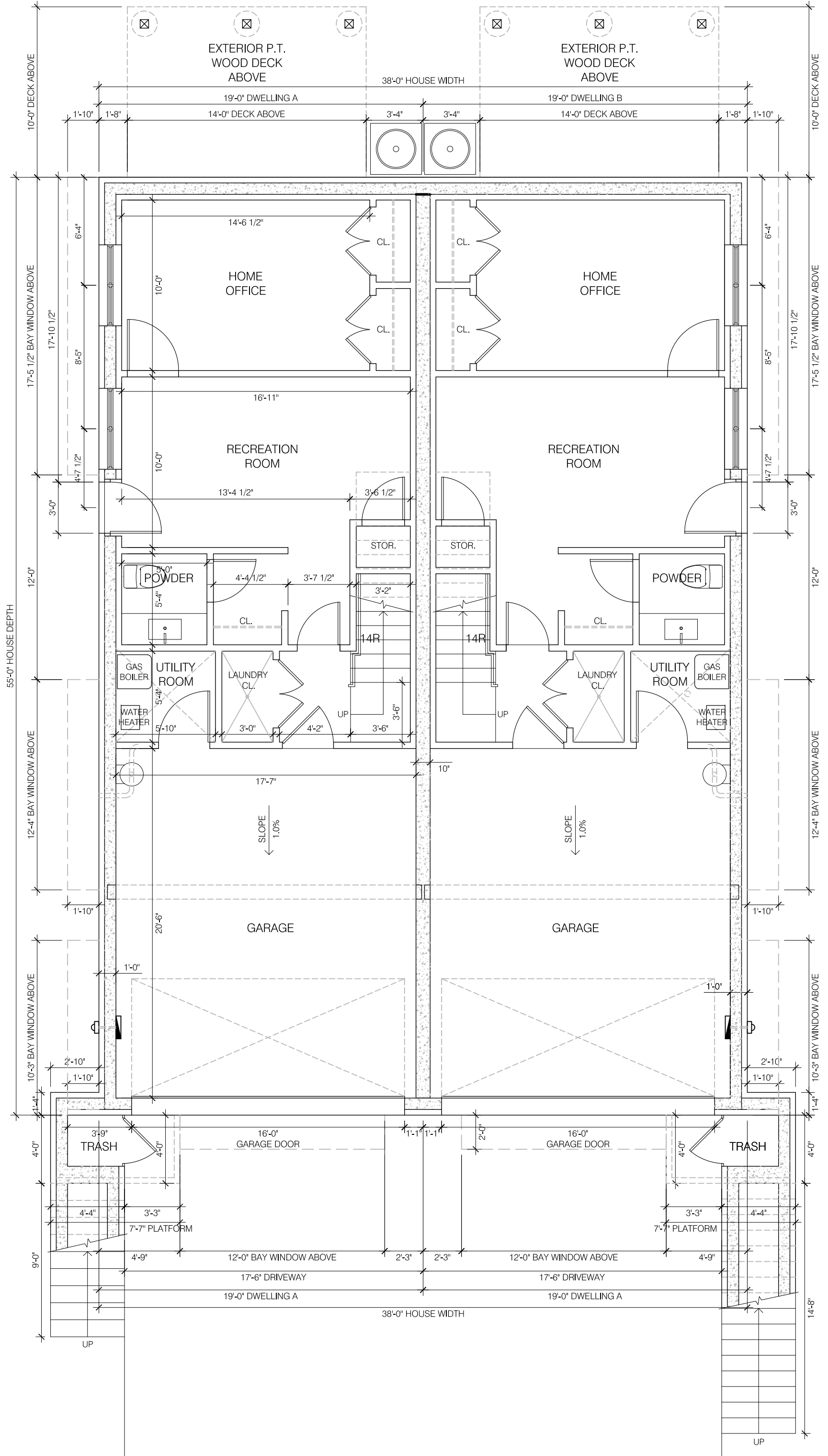

1 BASEMENT FLOOR PLAN  
SCALE: 3/16"=1'-0"

2 FIRST FLOOR PLAN  
SCALE: 3/16"=1'-0"

3 SECOND FLOOR PLAN  
SCALE: 3/16"=1'-0"

IT IS A VIOLATION OF NEW JERSEY STATE LAW TO ALTER PLANS, SPECIFICATIONS OR REPORTS TO WHICH THE SEAL OF AN ARCHITECT HAS BEEN APPLIED.

PROJECT TITLE  
**72 WEST RUBY AVENUE**

72 WEST RUBY AVENUE,  
PALISADES PARK, NEW JERSEY

CONSULTANT  
ARCHITECT  
**MG**  
ARCHITECTURE + URBANISM, LLC  
MG ARCHITECTURE URBANISM, LLC  
580 Sylvan Avenue, Suite 2C  
Englewood Cliffs, NJ 07632  
T:646.335.3515  
info@mg-ua.com

STAMP  
  
PETER C. PARK  
RA, AIA, NCARB, LEED AP ND  
NJ ARCHITECT: AI-20070

02	05.11.2021	ZONING REVIEW
01	01.29.2021	ENGINEER REVIEW
NO.	DATE	REVISION

DOB APPROVAL STAMP

DOB NO.

ISSUED DATE 05/11/2021

PROJECT NUMBER 20019

SCALE AS NOTED

SHEET NAME

FLOOR PLANS

SHEET NUMBER

**Z-102**

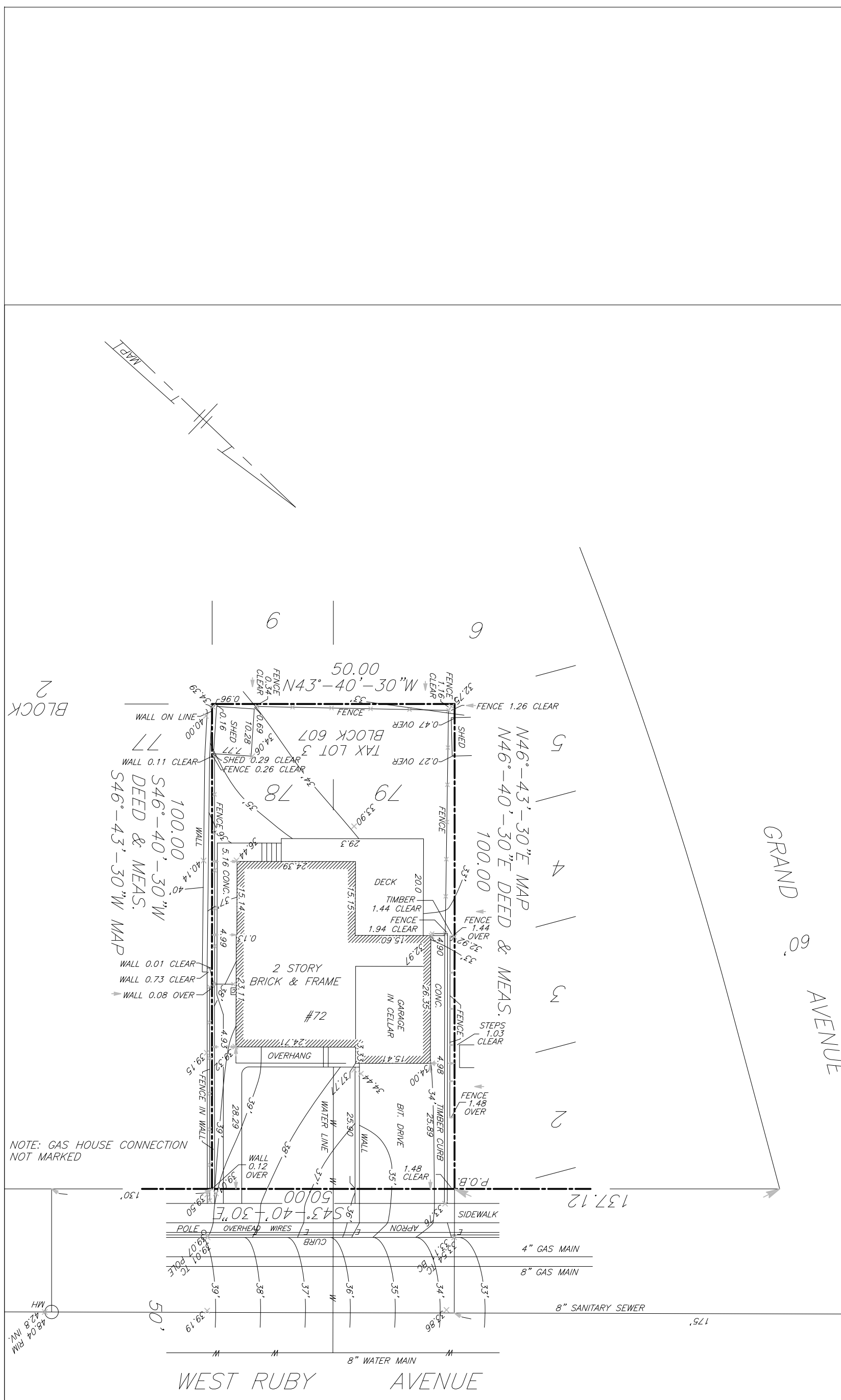

*SOIL MOVING REQUIREMENT	
AREA = 2,090 SF	
EXIST. BASEMENT = 1,040 SF.	
TOTAL OVERDIG AREA = 1,050 SF. X 1.5' = 1,575 SF.	204 YDS CUT
CUT = (1,575 SF) X (3.5 FT) = 5,513 CFT.	68 YDS FILL
BACKFILL = (1,575 - 1,050) X (3.5') = 1,838 CFT.	
DRIVEWAY CUT = 1,452 SF.	54 YDS CUT
SEEPAGE PIT CUT	35 YDS CUT
FILL	11 YDS FILL
TOTAL CUT	293 YDS CUT
TOTAL FILL	79 YDS FILL
NET SOIL REMOVED FROM THE SITE	214 YDS

5 SOIL MOVING REQUIREMENT  
SCALE: N.T.S.

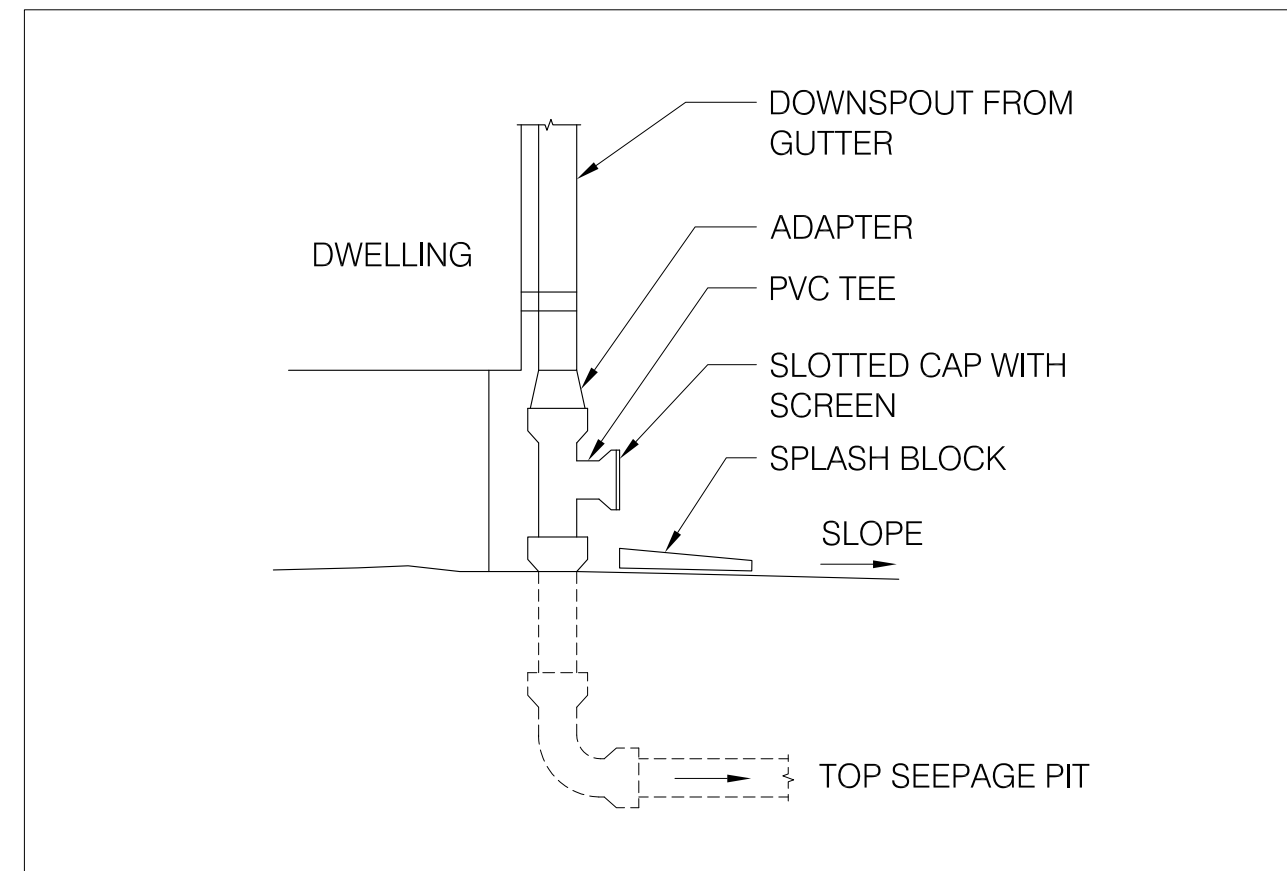

4 DOWNSPOUT DETAIL  
SCALE: N.T.S.

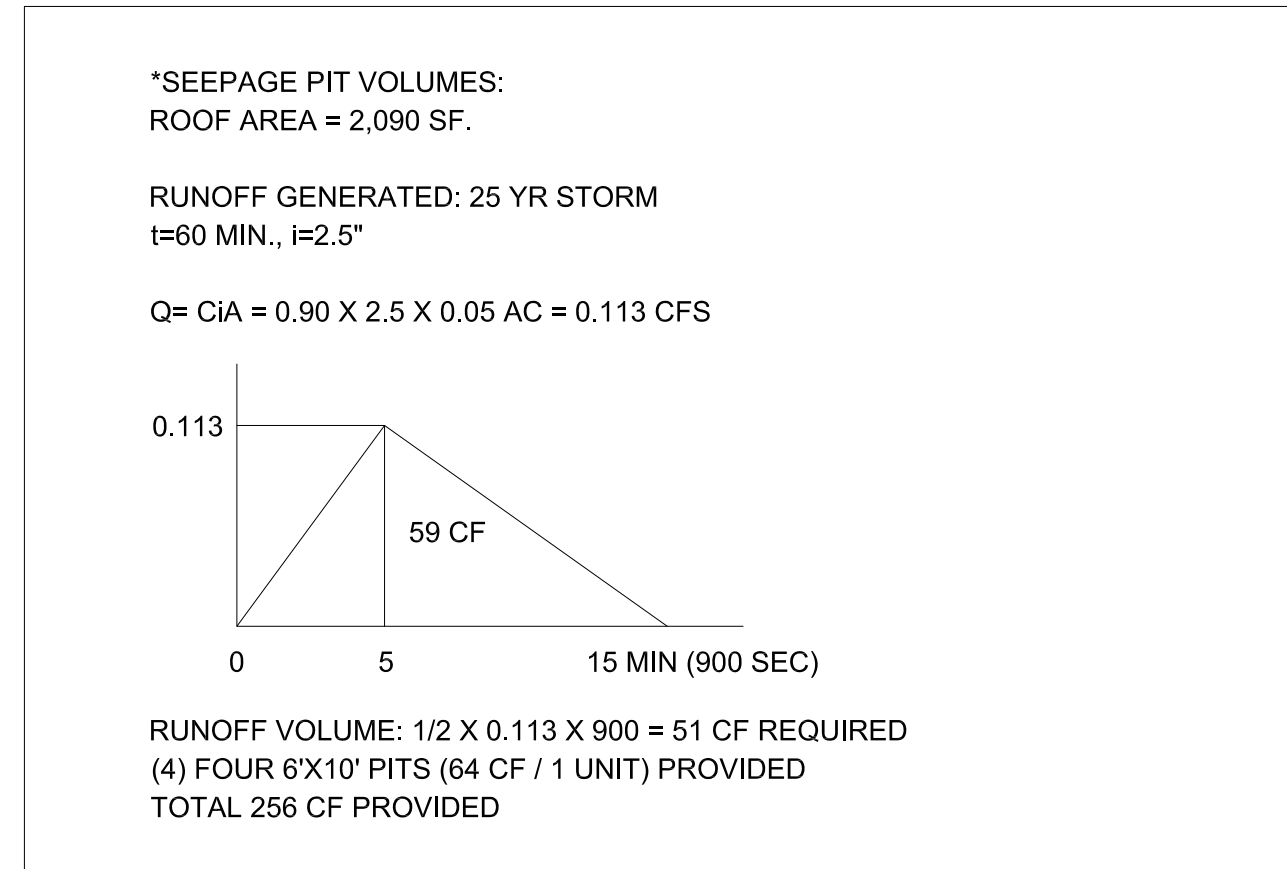

3 SEEPAGE PIT VOLUMES  
SCALE: N.T.S.

1 SITE SURVEYORS DRAWING  
SCALE: 1"=20'

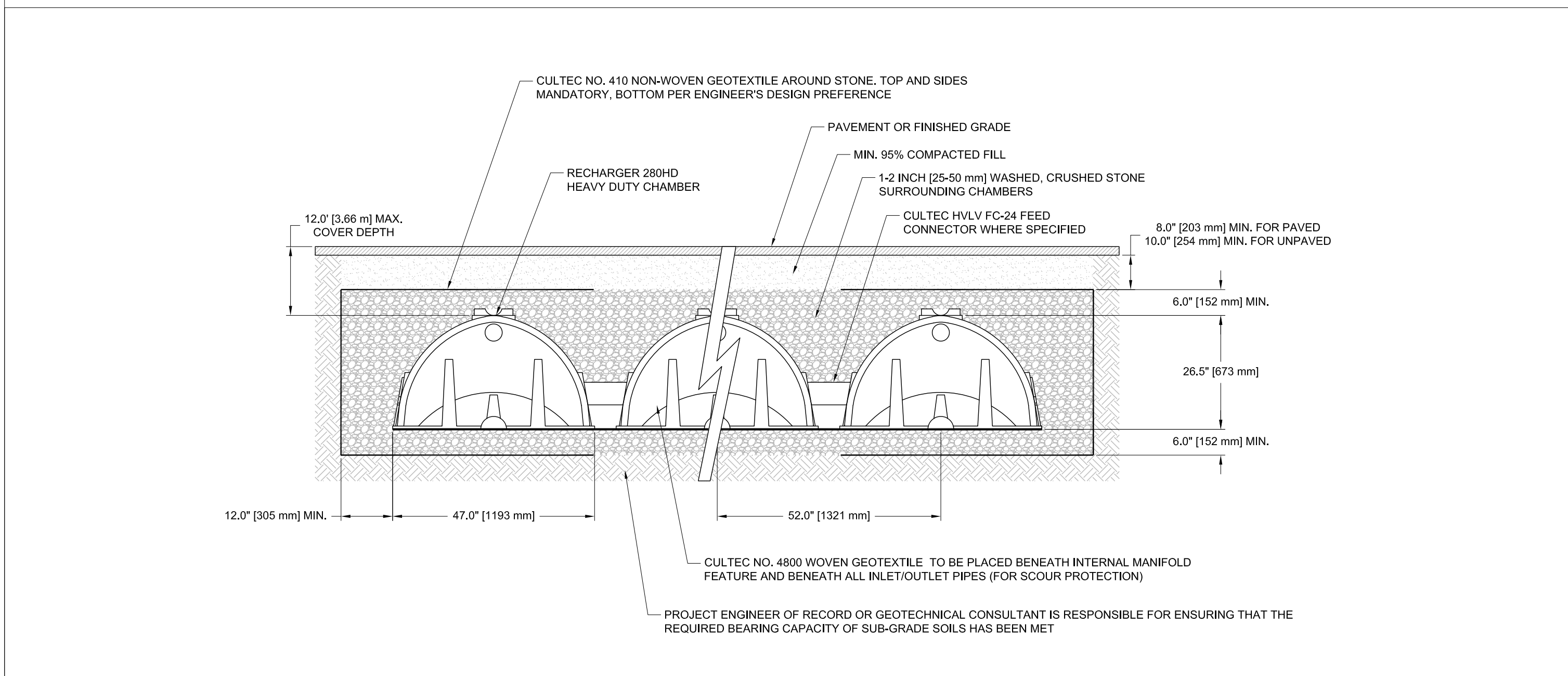

2 SEEPAGE PIT DETAIL  
SCALE: N.T.S.

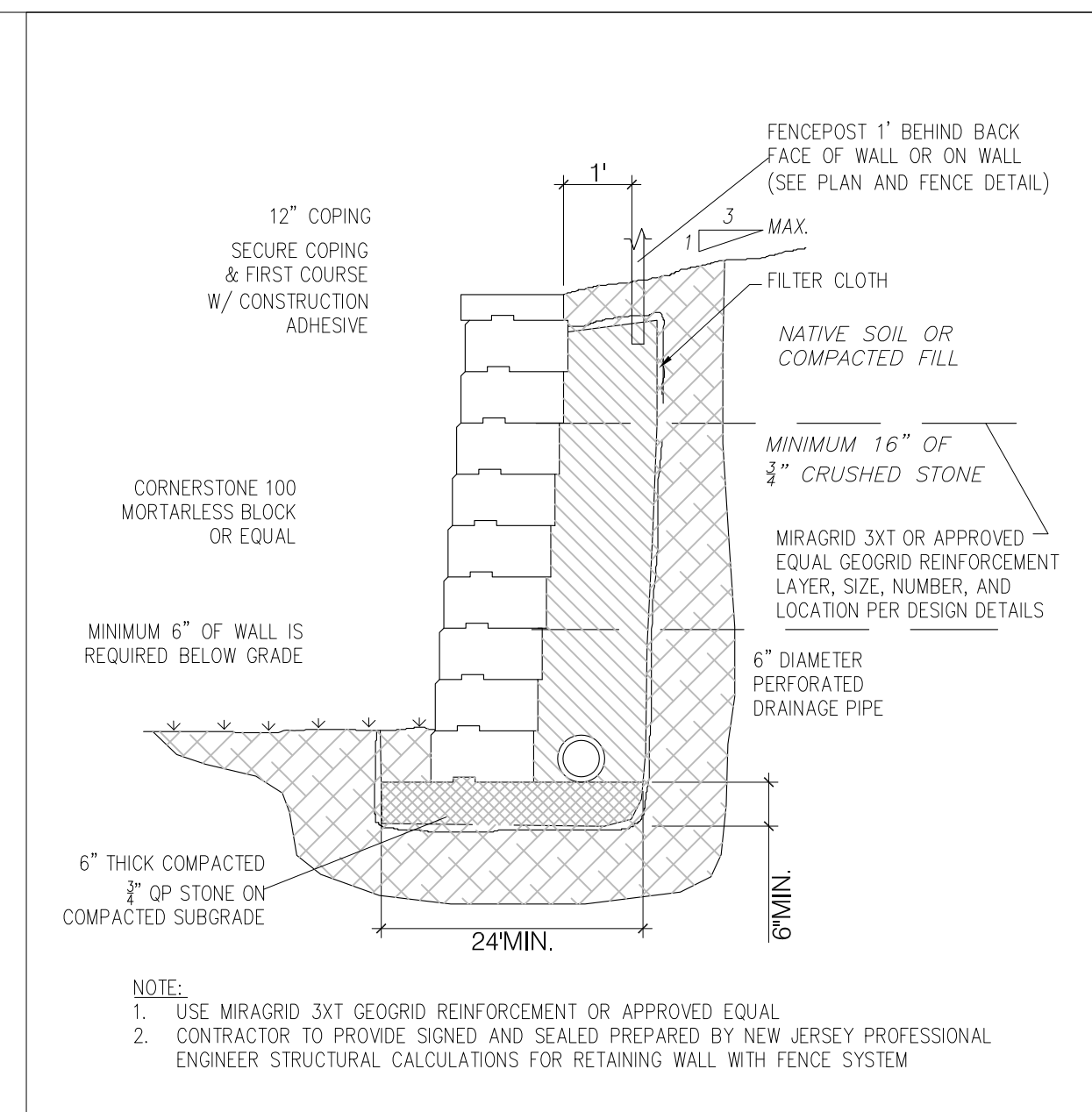

10 RETAINING WALL DETAIL  
SCALE: N.T.S.

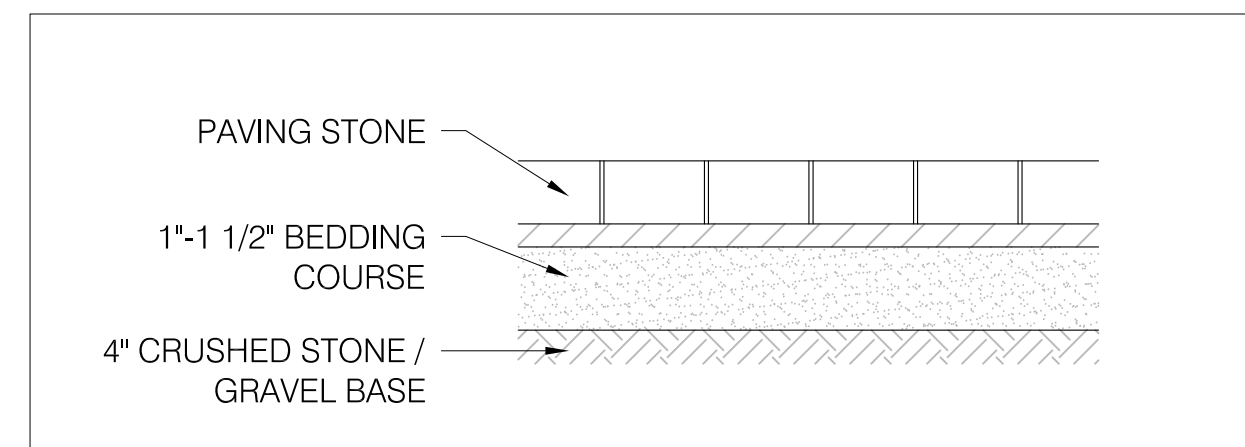

9 PAVER WALK DETAIL  
SCALE: N.T.S.

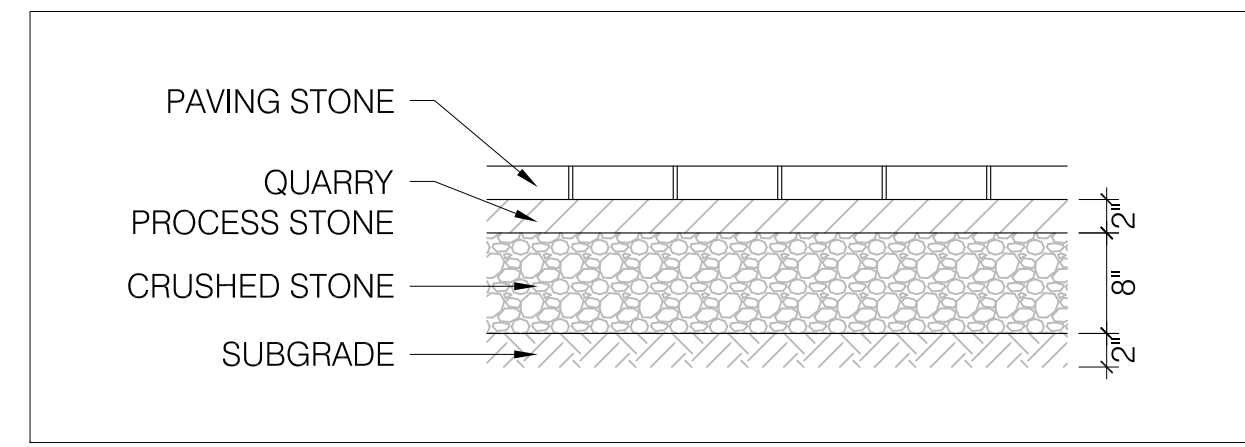

8 PAVER DRIVEWAY DETAIL  
SCALE: N.T.S.

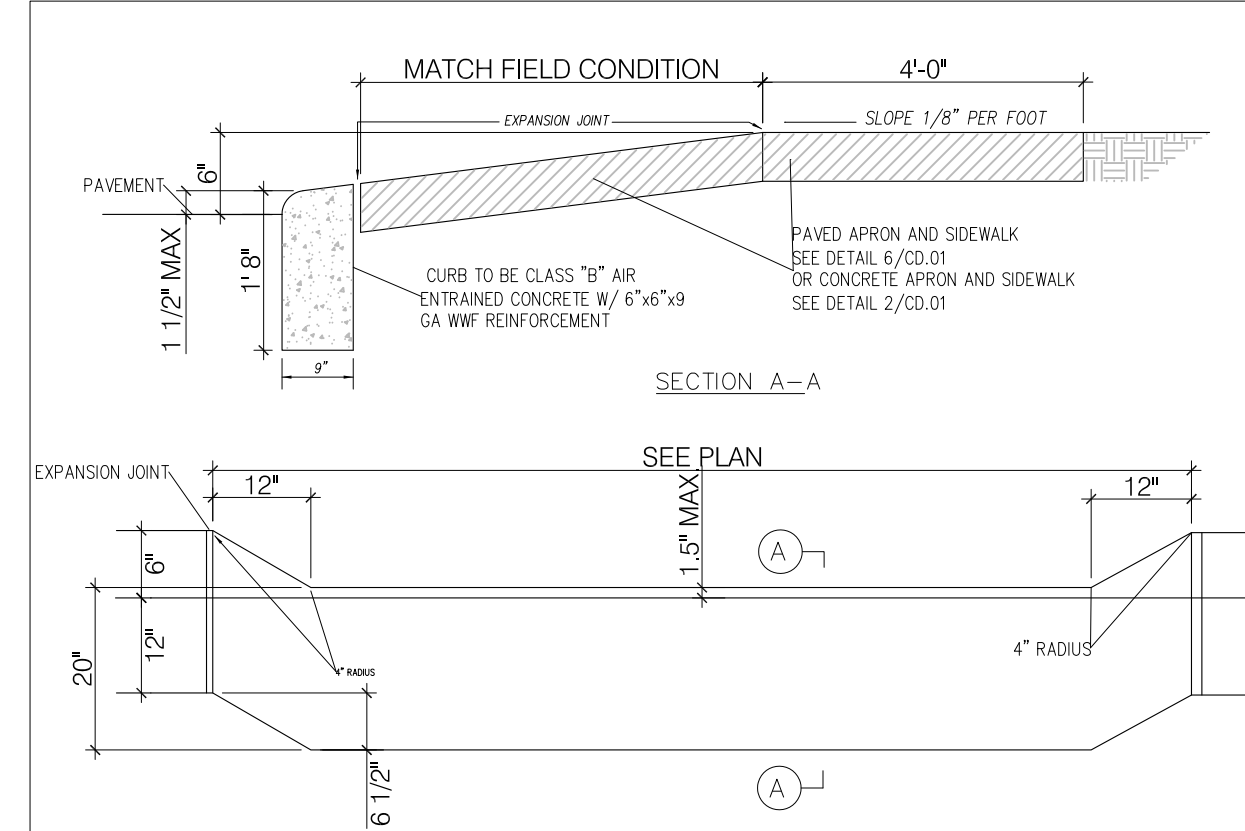

7 DRIVE APRON DETAIL  
SCALE: N.T.S.

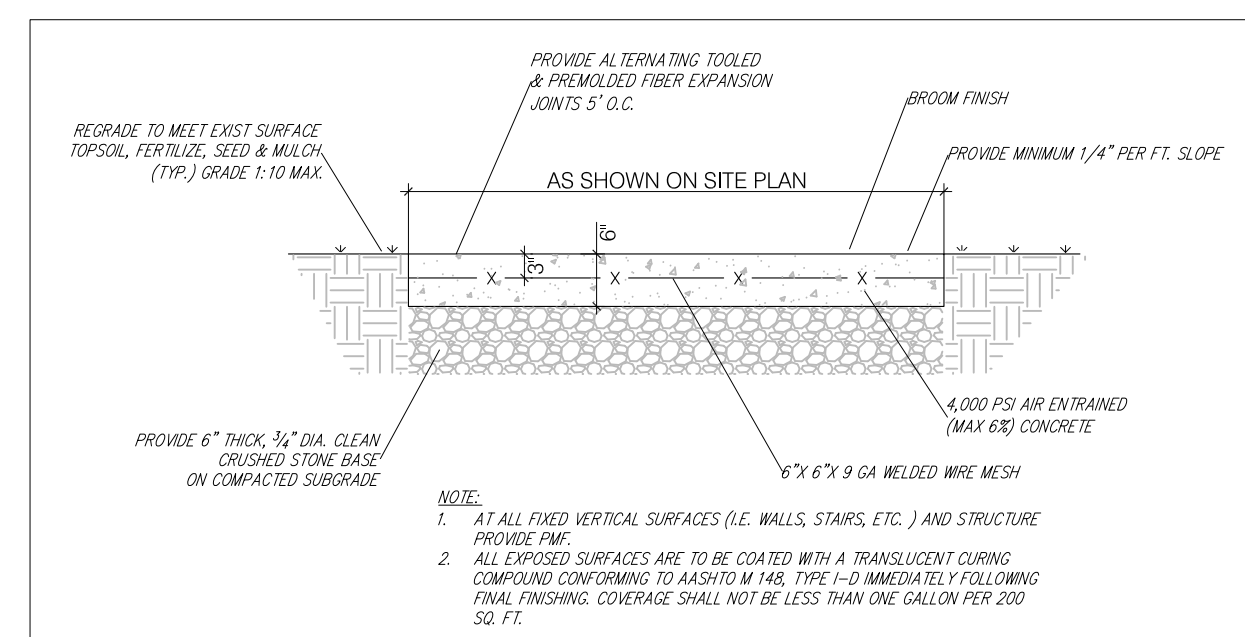

6 CONC. SIDEWALK DETAIL  
SCALE: N.T.S.

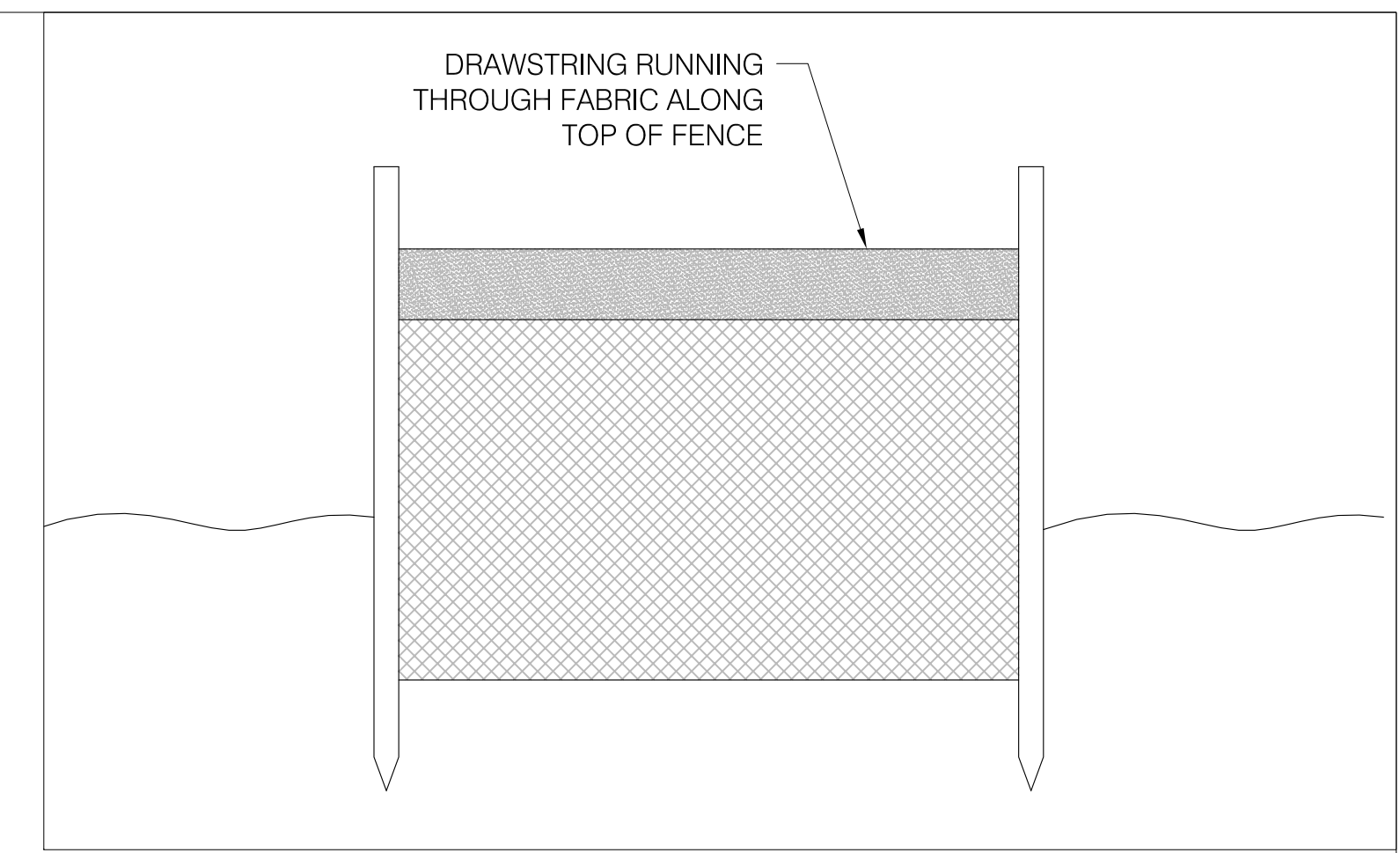

12 SILT FENCE DETAIL  
SCALE: N.T.S.

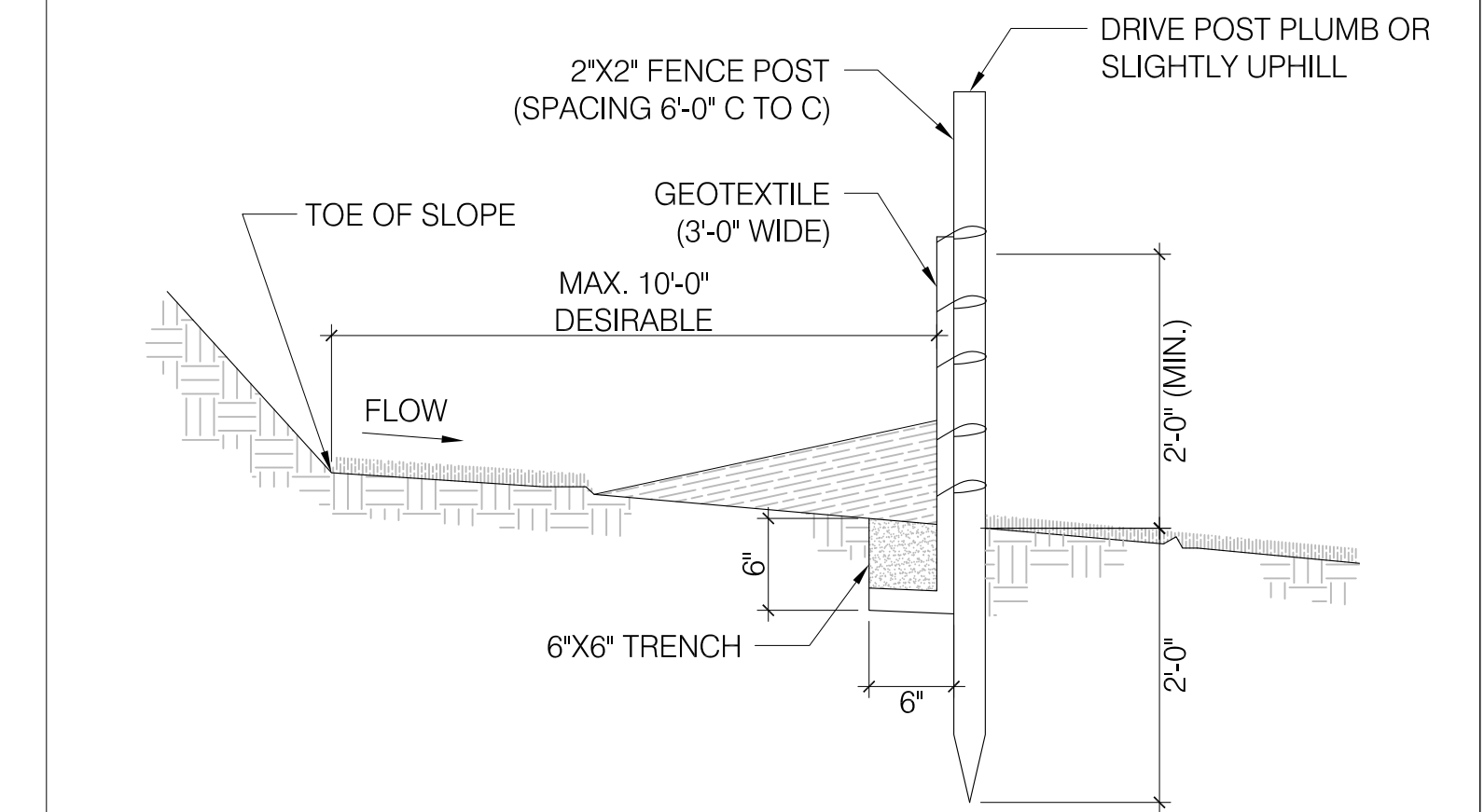

11 SILT FENCE DETAIL  
SCALE: N.T.S.

- NOTES:
- SECURELY FASTEN GEOTEXTILE TO FENCE POST BY USE OF WIRE TIES, HOG RINGS, STAPLES, OR POCKETS. FOUR TO SIX FASTENERS PER POST.
  - BURY BOTTOM 1'-0" OF GEOTEXTILE AND TAMP IN PLACE.
  - SECURELY FASTEN ENDS OF INDIVIDUAL ROLLS OF GEOTEXTILE TO A POST BY WRAPPING EACH END OF THE GEOTEXTILE AROUND THE POST TWICE AND ATTACHING AS SPECIFIED IN NOTE 1 ABOVE. DO NOT SPLICE INDIVIDUAL ROLLS AT LOW POINTS.
  - SET SILT FENCE WITHIN PROJECT LIMITS. 10'-0" IS DESIRABLE.

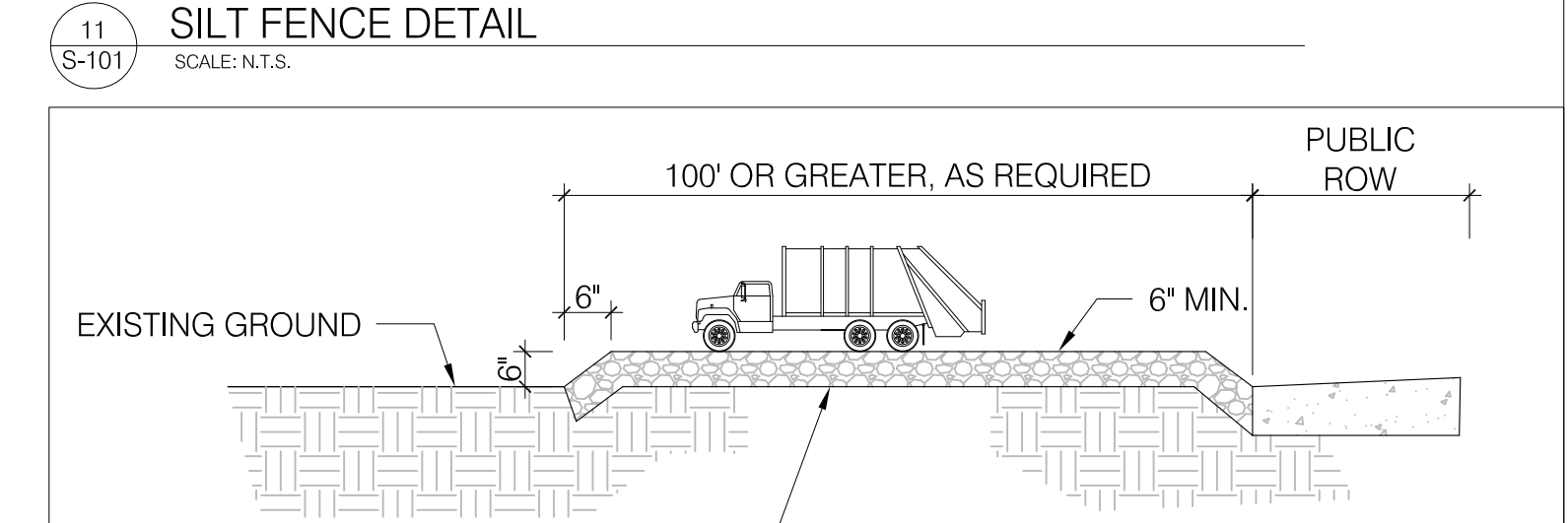

10 STABILIZED CONSTRUCTION DRIVEWAY  
SCALE: N.T.S.

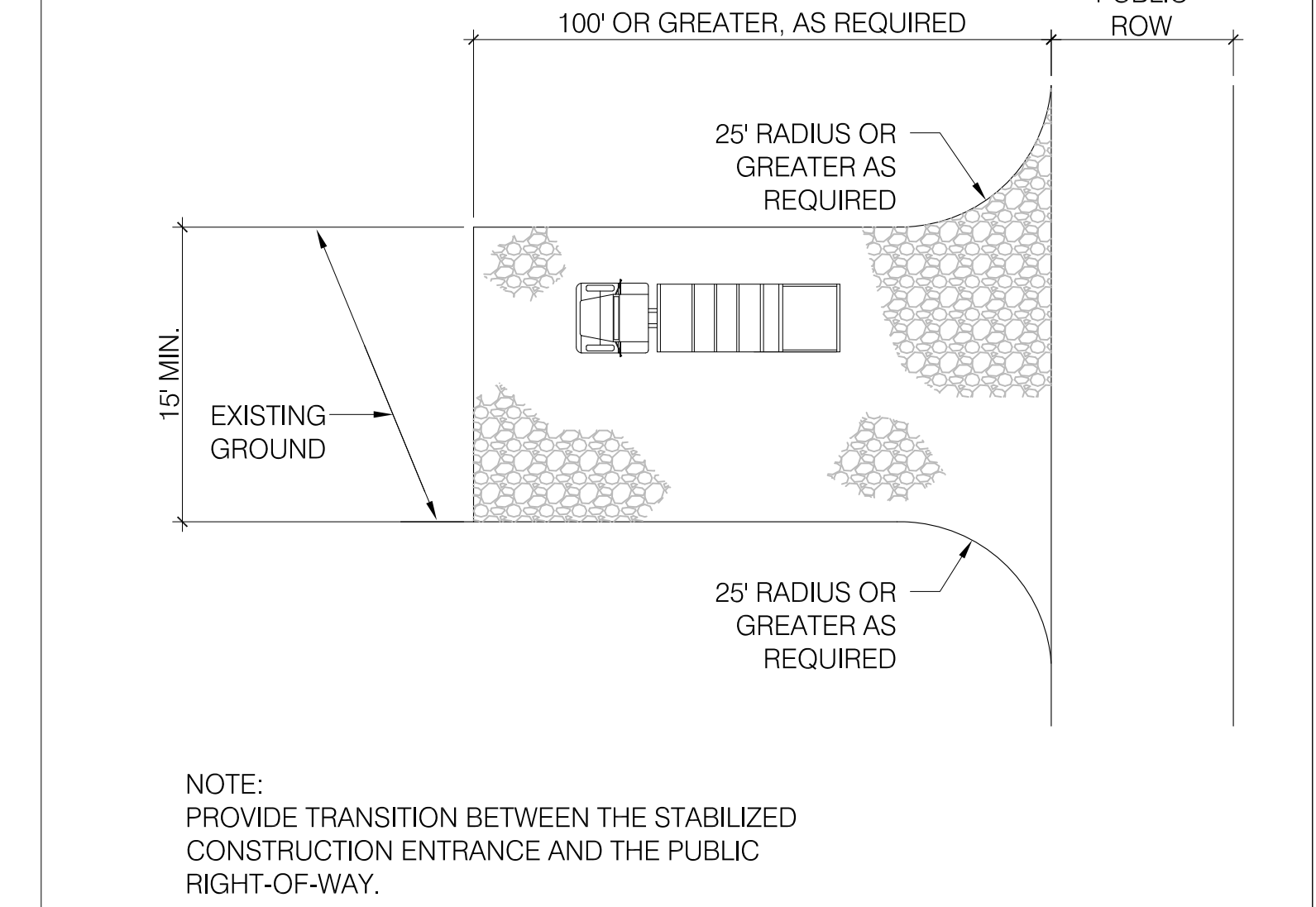

10 STABILIZED CONSTRUCTION DRIVEWAY  
SCALE: N.T.S.

IT IS A VIOLATION OF NEW JERSEY STATE LAW TO ALTER PLANS, SPECIFICATIONS OR REPORTS TO WHICH THE SEAL OF AN ARCHITECT HAS BEEN APPLIED.

PROJECT TITLE  
**72 WEST RUBY AVENUE**  
72 WEST RUBY AVENUE, PALISADES PARK, NEW JERSEY

CONSULTANT  
ARCHITECT  
**MG**  
ARCHITECTURE + URBANISM, LLC  
MG ARCHITECTURE URBANISM, LLC  
580 Sylvan Avenue, Suite 2C  
Englewood Cliffs, NJ 07632  
T.646.335.3515  
info@mg-ai.com

SURVEYOR  
GLUCKLER & DEN BLEYKER  
Professional Land Surveyors  
310 Hudson Street, Hackensack, NJ 07601  
T.201.343.3777  
NOTE: Site plan and zoning information taken from the survey drawing prepared and issued by Gluckler & Den Bleyker.

STAMP

PETER C. PARK  
RA, AIA, NCARB, LEED AP ND  
NJ ARCHITECT: AI-20070

NO.	DATE	REVISION
02	05.11.2021	ZONING REVIEW
01	01.29.2021	ENGINEER REVIEW
NO. 1	DATE	REVISION

DOB APPROVAL STAMP

DOB NO.

ISSUED DATE 05/11/2021

PROJECT NUMBER 20019

SCALE AS NOTED

SHEET NAME

**SITE SURVEYOR'S DRAWING AND DETAILS**

SHEET NUMBER

**S-101**